

Forma Close Coupled 4.5/3 litre Cistern

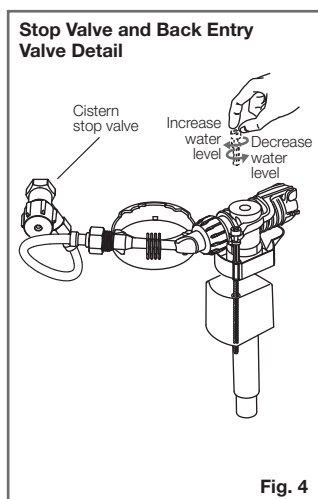
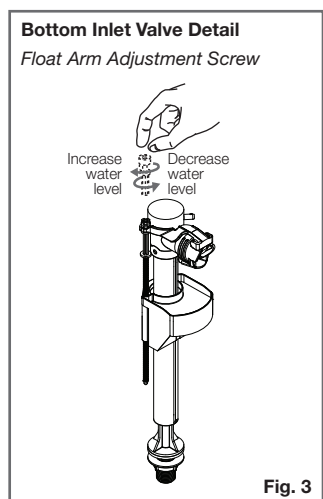
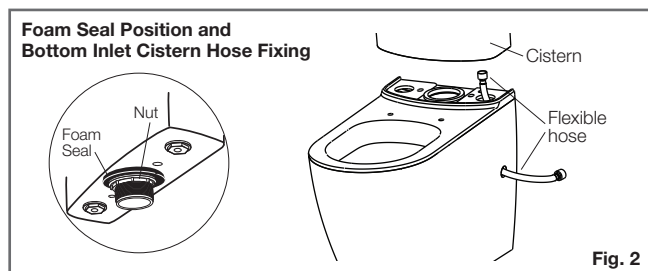
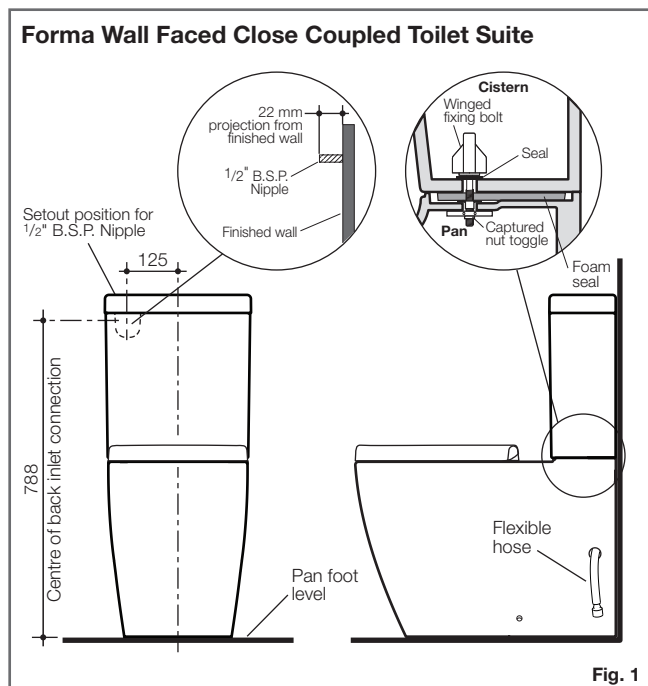

Note: The inlet valves are suitable for dynamic flow pressures of 30 kPa to 1000 kPa.

PLUMBERS' INSTALLATION INSTRUCTIONS

**PLEASE READ CAREFULLY BEFORE INSTALLATION
THESE CISTERN INSTRUCTIONS SUPERSEDE
INSTRUCTIONS IN THE PAN CARTON**

CISTERN FIXING PROCEDURE

Standard right hand bottom inlet (Internal overflow only) installation

The inlet valve can be changed from left to right or vice versa.

Note: The cistern fixes directly to the pan with a robust base fixing system without the need for wall fixing.

- 1- Ensure the foam seal at base of cistern is securely attached to cistern base, as detailed in Fig. 2.
- 2- Connect flexible hose to inlet valve and thread other end of flexible hose through side hole on pan, as detailed in Fig. 2. Position cistern onto pan and align the cistern fixing holes with the threaded fixing holes located in the cistern platform.
- 3- Fit the seals into the winged fixing bolts, as detailed in Fig. 1. Twist and remove main top section of outlet valve to access bottom of cistern.
- 4- Insert the winged fixing bolts through the cistern fixing holes into the threaded fixing holes located in the pan. Gradually tighten the left and right hand nuts by hand to firmly secure the cistern to pan, as detailed in Fig. 1. Replace outlet valve ensuring orientation is correct.
- 5- Flush the lines before connecting the flexible hose to the stop tap.
- 6- Adjusting water level: Turn on water mains. Open the cistern stop valve and check the operation of the mechanisms and valve. Adjust water level to the water level mark inside the cistern by simply turning the float arm adjustment screw in a clockwise or anti clockwise direction as detailed in Fig. 3.
- 7- Fit cistern lid to check push button operation to complete installation.

IMPORTANT: THE STANDARD INLET VALVE IS FITTED WITH A LINE STRAINER. ITS TAIL IS CENTRALLY LOCATED TO ALLOW EASY REMOVAL FOR CLEANING. THIS TAIL FITS EASILY INTO THE COPPER CONNECTION PIPE. INSTALLATION OF THE CISTERN WITHOUT THE STRAINER CAN LEAD TO DAMAGE OF THE INLET VALVE FROM THE WATER-BORNE CONTAMINANTS LEADING TO CISTERN MALFUNCTION.

Back Entry installation

- 1- Securely attach the self-adhesive foam seal around the outlet on the base of cistern, as detailed in Fig. 2. Remove inlet valve to gain access to the right hand cistern fixing hole.
 - 2- Position cistern onto pan, and align the cistern fixing holes with the threaded fixing holes located in the cistern platform.
 - 3- Ensure that the back inlet water connection nipple is aligned with the cut out in the back of the cistern. Fit the seals onto the winged fixing bolts.
 - 4- Insert the winged fixing bolts through the cistern fixing holes into the threaded fixing holes located in the pan. Gradually tighten the left and right hand nuts by hand to firmly secure the cistern to pan, as detailed in Fig. 1.
 - 5- Fit cistern stop valve (supplied) to the 1/2" B.S.P. nipple in the wall using approved thread seal as detailed in Fig. 4. Connect one end of flexible hose to cistern stop valve.
- Note:** As specified in Australian Standard AS/NZS 3499, flexible hose assemblies shall not be submerged.
- 6- Refit the inlet valve into position.
 - 7- Flush the lines before connecting the flexible hose to the stop tap and ensure the hose is not rubbing against the inside of the cistern.
 - 8- Turn on water mains. Open cistern stop valve and check for leaks and operation of mechanisms and valves. Ensure there is no leakage from the cistern into the pan.
 - 9- Adjust water level to the 4.5 litre water level mark inside the cistern by simply turning the float arm screw in a clockwise or anti-clockwise direction, as detailed in Fig. 4.
 - 10- Fit cistern lid to check push button operation to complete installation.



IMPORTANT

TO ACHIEVE A SATISFACTORY 4.5/3L FLUSH PERFORMANCE AND A 4 STAR WATER EFFICIENCY RATING THE CISTERN MUST BE MATCHED WITH A COMPATIBLE CAROMA SMARTFLUSH 4.5/3L TOILET PAN.